



Standex-Meder Electronics

Custom Engineered Solutions for Tomorrow



Liquid Level Sensor Overview

Product Training

Introduction

Purpose

- Present the different types of liquid level sensors explore their sensing applications

Objectives

- Present the liquid level sensing technology
- Define the key functions and key terms
- Present the various package configurations
- Present the varied applications





Introduction

- Level sensing approaches
- Inductive sensing
- Mechanical sensing
- Reed switch sensing

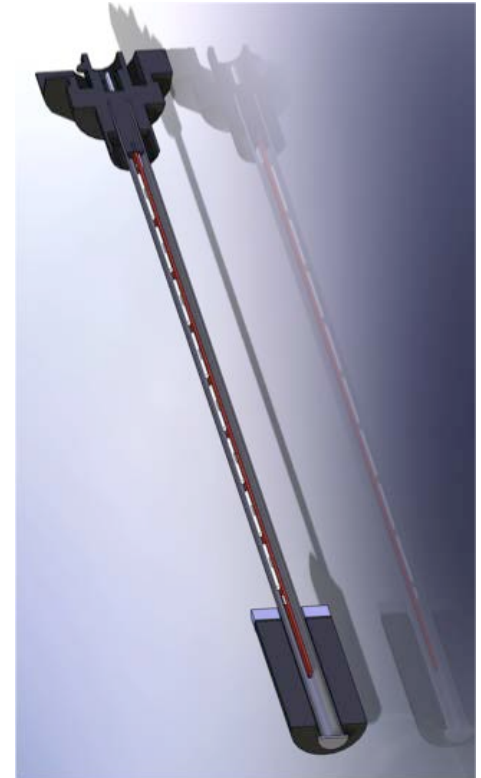

The Liquid Level Reed Sensor

- The sensors make-up
- Its basic function

Click to Animate

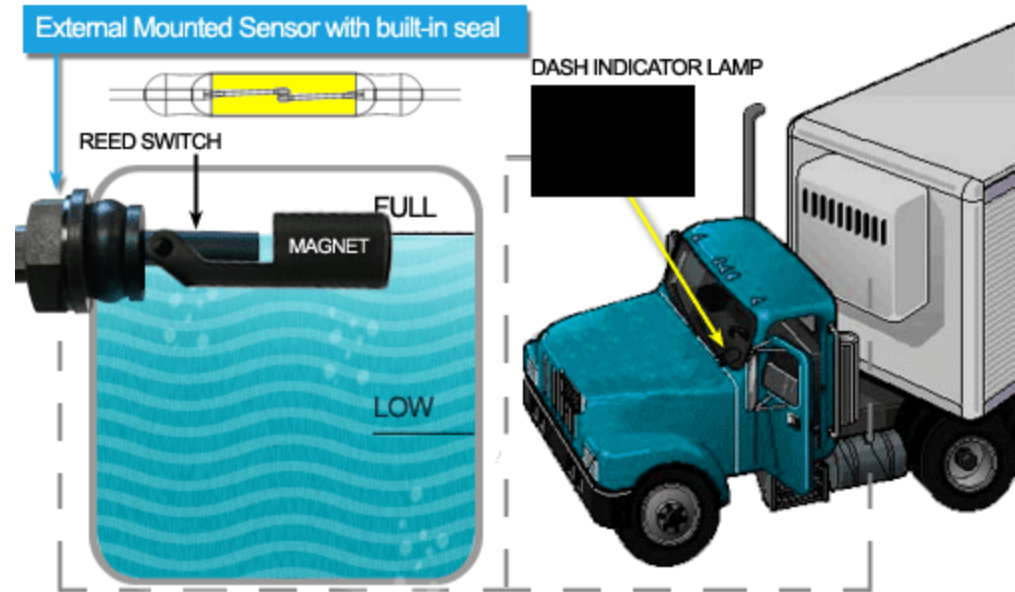



Key Sensor Points

- Liquid Level Reed Sensors becoming the technology of the future
- Draws no power
- Ideal for battery applications





Key Sensor Points



- Hermetically sealed reed switch
- Packaged in rugged plastic and epoxy
- Also optionally packaged in stainless steel





Key Sensor Points

- Remote operation
- Contacts capable of switching millions of operations
- Magnet mounting

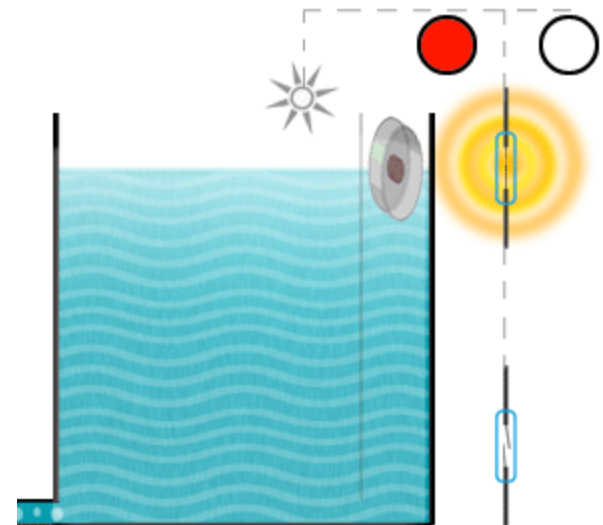

Click to Animate

Key Aspects of the Sensor

- The simplest reed level sensor
 - ▣ A reed switch is needed
 - ▣ A magnet is needed

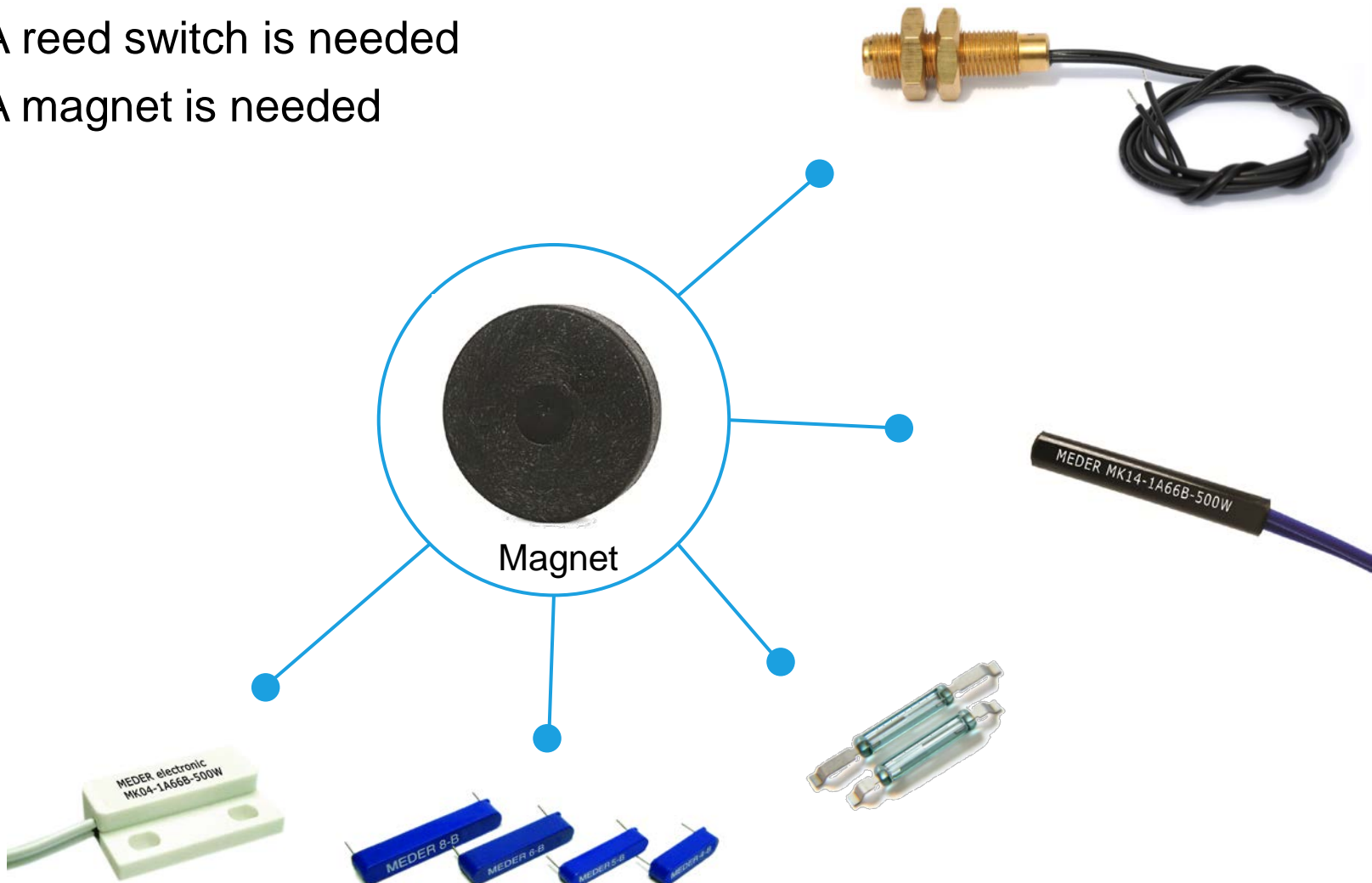

Key Aspects of the Sensor

- The Stem
- The Float(s)
- Reed switch(es) housed in the stem



Switching Configurations

- ❑ Single pole normally open
- ❑ Single pole normally closed
- ❑ Single pole latching
- ❑ Single pole double throw
- ❑ Multi-pole single throw





Types of Plastic

- Polypropylene (PP) – water, mild acids
- Polyamide (PA) – oil, gas, brake fluid
- Nitrile Butadiene Rubber (NBR) – oil, gas, high temperatures



Liquid Level Reed Sensor Key Features

- All inclusive fluid level sensor having the sensing element (reed switch), float, and magnet all as one component
 - LS04 Plastic Series (multi-level)
 - Up to 9 point liquid level sensing
 - Up to 6 active floats on one stem or shaft
 - Stem length for 100 mm to 250 mm
 - LS05 Stainless Steel Series (multi-level)
 - Any number of points liquid level sensing
 - Any number of floats on one stem or shaft
 - Stem length for 80 mm to 2,000 mm
- Ability to perform under hot and cold liquid systems
- Meets RoHS Directive 2002/95/EC
- Hermetically sealed
- Dynamically tested contacts
- Reliable switching





Liquid Level Applications



A Look at a Multiple Sensing Point Application

- ❑ Multiple sensing points
- ❑ Stem circuitry

Customize the LS05 Series with any number of sense points to provide continuous liquid level monitoring.

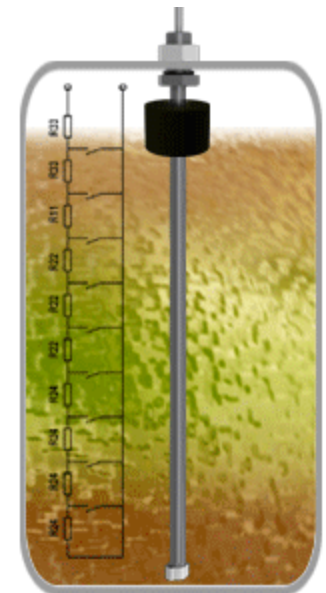
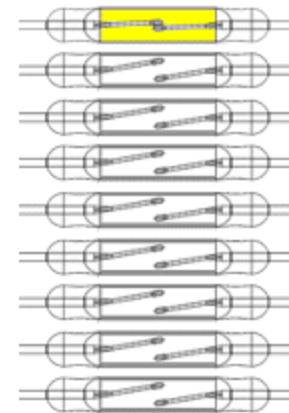
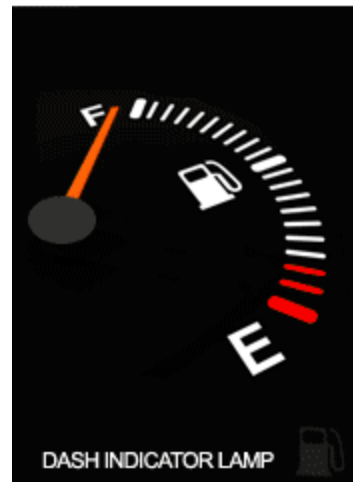

Click to Animate

Laboratory Applications

- Laboratory fluid systems
- Four sensing positions
- Three are dedicated to monitoring hot fluid levels
- The fourth senses a low fluid level cutoff point.

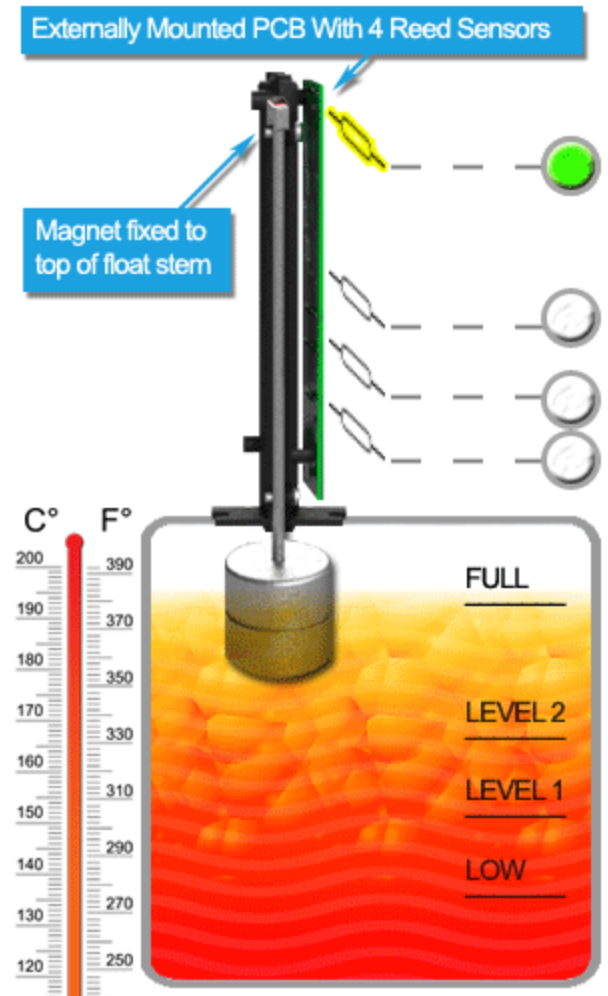

[Click to Animate](#)



Wide Variety of Liquid Level Monitoring

- Liquid systems all have their own specialty aspects
- Different liquids have different densities
- Liquid environments range in temperature from -40oC for flour-inert (3-M liquids) to 200oC
- Pressure heated water and other special liquids

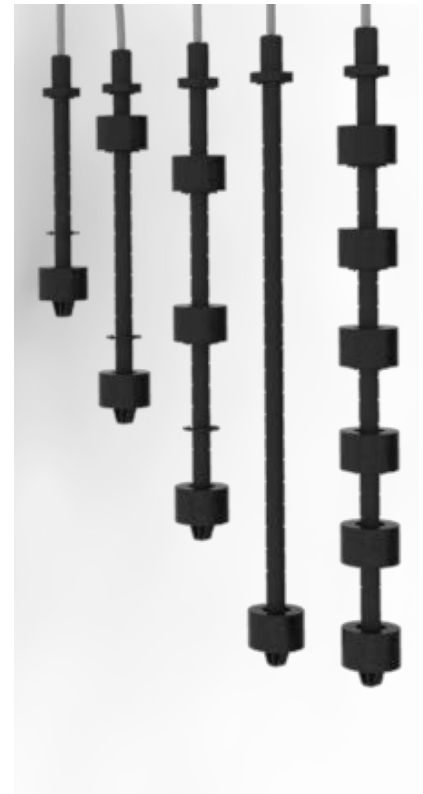

Automotive Applications

- ❑ Fuel sensor
- ❑ Engine oil
- ❑ ABS-system
- ❑ Radiator
- ❑ Window washer
- ❑ Power steering fluid
- ❑ Fuel filter for diesel
- ❑ Oil and fuel sensors for construction and agricultural vehicles

Click to Animate

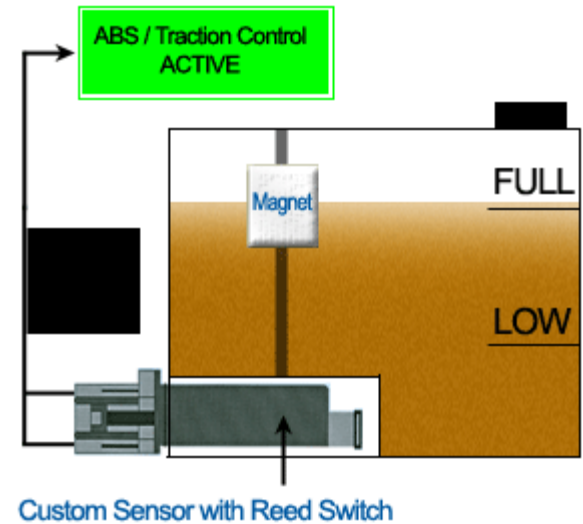

Aerospace and Marine Industry

- Fuel tank gauge
- Fuel sensor for rockets
- Fuel valves
- Sensor for liquid propane gas (LPG) ships
- Fuel sensor for Jet Ski
- Oil level sensor for Jet Ski
- Fuel gauge for tanker

Magnets built into the floats move over the switch activating the LED level indicators

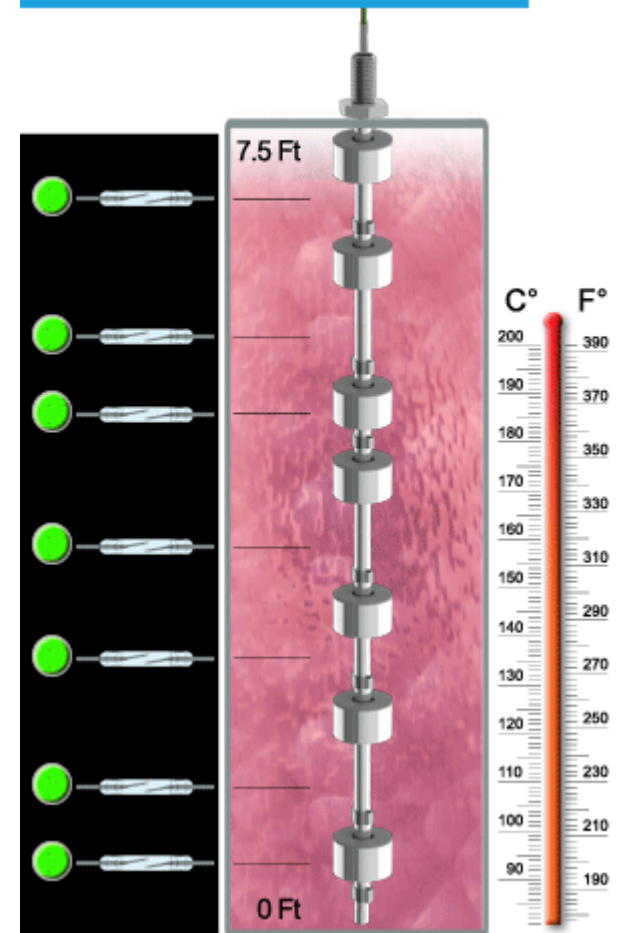

[Click to Animate](#)

Industrial Requirements

- ❑ Liquid level sensor in factories
- ❑ Water seal float
- ❑ Oil level gauge for transformers
- ❑ Air-leak valve for underwater applications
- ❑ Boiler control
- ❑ Auto-drain for pneumatic filters
- ❑ Lubricating units
- ❑ Generators
- ❑ Gasoline pump fuel dispensers
- ❑ Gasoline underground tanks

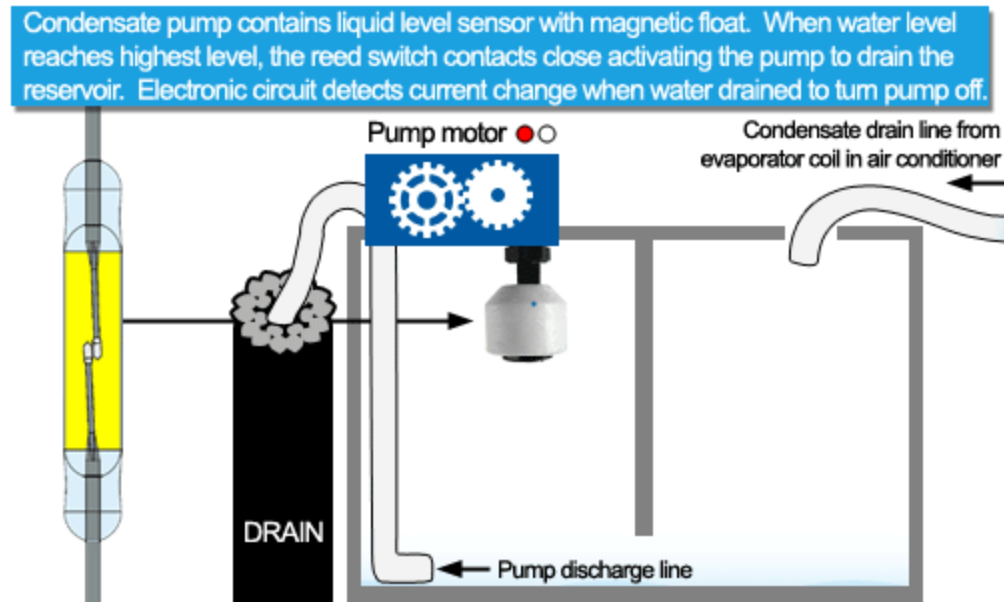

Click to Animate

Various Electrical Equipment

- ❑ Humidifiers
- ❑ Copiers
- ❑ Automatic bending machines
- ❑ Water cleaners
- ❑ Detection of the liquid level for two different kinds of specific gravity liquids
- ❑ Water wash rug cleaners
- ❑ Developer for pictures
- ❑ Oil baths for testing instruments
- ❑ Atomic power plant liquid level applications

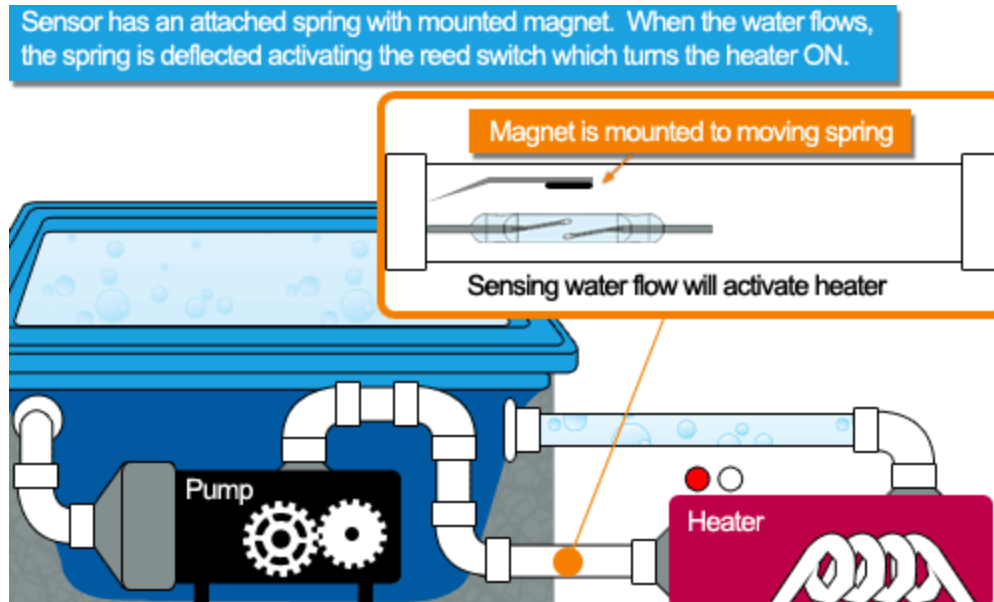

Click to Animate

Home Appliances

- ❑ Stoves
- ❑ Air-conditioners
- ❑ Solar systems
- ❑ Fan-heaters
- ❑ Saunas
- ❑ Dish washers
- ❑ Showers and toilets that have electric water pumps
- ❑ Cleaning machines

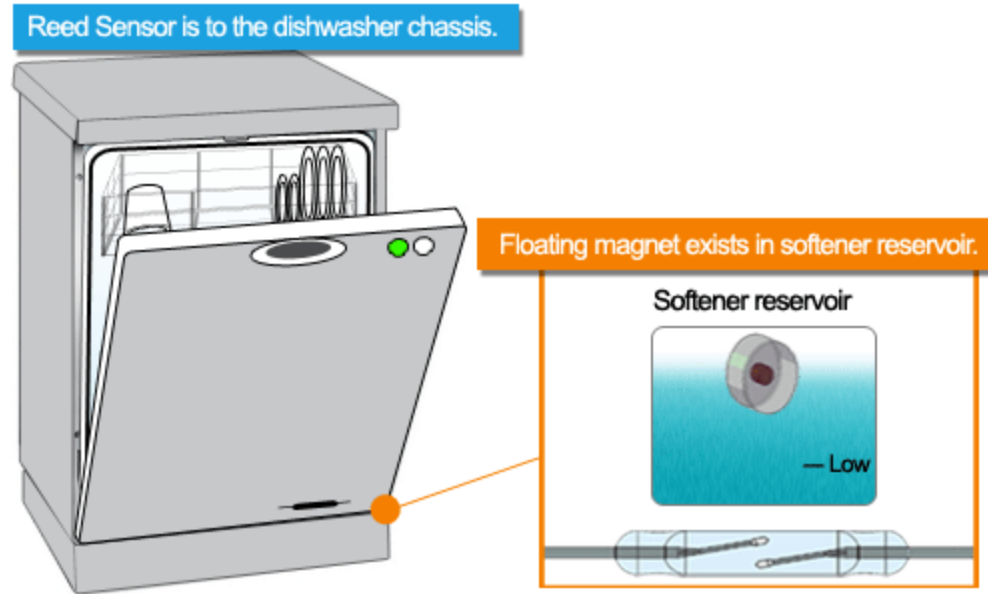

Click to Animate



Summary

- Each technology has its own best operating characteristics
- Liquid level detection continues to increasingly select the liquid level reed sensor because of its favorable characteristics and versatile design capabilities over the other technologies.

PARTNER | SOLVE | DELIVER

For more information on our capabilities, and how we can partner, solve, and deliver to your needs, please visit us at www.standexmeder.com